



Model AS-9234E
Installation Manual
Vehicle Security System
With Remote Start

Table Of Content:

Before You Begin	Page 2
Wire Harness Quick View	Pages 3 & 4
Mounting Of The Major Components	Page 5
6 Pin Power Harness Wiring	Pages 6 & 7
22 Pin Accessory I/O Harness	Pages 8 - 14
2 Pin Door Lock Harness Wiring	Pages 15 - 17
4 Pin Gnd, Park Light & Siren Harness	Pages 14 & 15
Timed Start Programming & Operation	Page 18
Optional RF Data Converter Kit	Pages 6, 18, & 27
Diesel Set Up And Programming	Page 19
Monitoring The Vehicle's Engine	Page 19
Tach Programming	Pages 19 & 29
Diagnostics	Page 20
Multi Coil Pack Adapter	Page 20
Testing Your Installation	Pages 21 - 24
Remote Start Override	Page 21
Dome Delay Learn Routine	Page 25
Adjusting The Shock Sensor	Page 25
Completing Your Installation	Page 25
Shock Sensor Selections While Remote Starting	Page 26
Programming Transmitters	Page 27
Programming Alarm Feature Bank 2	Pages 27 & 28
Programming Remote Start Features Bank 3	Pages 29 & 30
Circuit Wiring Diagram	Page 31

PATENTED: www.voxxintl.com/company/patents

Before You Begin

PROFESSIONAL INSTALLATION IS STRONGLY RECOMMENDED

Roll down window to avoid locking the keys in the vehicle during installation

Avoid mounting components or routing wires near hot surfaces or near moving parts like the steering wheel as it may prevent proper operation of the vehicle

Tape or loom wires under the hood and dash for protection as well appearance

Use grommets when routing wires through metal surfaces to prevent chafing and shorting

Use a Digital Multi Meter for testing and verifying circuits. **DO NOT USE A "TEST LIGHT" OR "COMPUTER SAFE PROBE"** as these can set off air bags or damage sensitive vehicle computers and electronics

**For technical support go to www.avxtech1.com
or call 1 800 225 6074**

This device complies with FCC Rules Part 15 Operation is subject to the following two conditions

(1) This device may not cause harmful interference and

(2) This device must accept any interference that may be received, including interference that may cause undesired operation.

NOTE:The manufacturer is not responsible for any radio or TV interference caused by unauthorized modifications to this equipment. Such modifications could void the user's authority to operate the equipment

22 Pin Main I/O Wiring Harness #1124343	
1 Orange	Ground While Armed Output (-)
2 Green/Yellow	Diesel Wait To Start Input
3 Dk. Blue/Black	External Remote Start Trigger Input (-)
4 Gray	Hood Pin Shutdown Input (-)
5 Brown/Black	Brake Shutdown Input (+)
6 NC	
7 Green	Arm 1 (Polarity Learn - or +)
8 Yellow/Black	To Factory Alarm Ignition Input
9 Black/Red	Pulse After Shutdown (-)
10 Black/Blue	Factory Disarm / Pulse Before Start (-)
11 Black/Yellow	Pulse During Crank (-)
12 Green/Orange	Tachometer Input
13 Dk Green	Instant Trigger Input Hood & Trunk(-)
14 Brown	Door Trigger Input (-)
15 Purple	Door Trigger Input (+)
16 Blue	Trunk Shunt Bypass Input (+)
17 Red/Black	Disarm 2 (Polarity Learn - or +)
18 Red	Disarm 1 (Polarity Learn - or +)
19 Green/Black	Arm 2 (Polarity Learn - or +)
20 Black/White	Horn Output (-) 300mA
21 Light Blue	Ground Output While Running (-) 300mA
22 Black/Lt. Green	Factory Arm / Pulse After Start (-)
2 Pin Door Lock Output Harness #1122242	
1 Red	(-) Lock Output 300mA
2 Green	(-) Unlock 300mA
6 Pin Power / Start Harness #1123742	
1 Blue	Ignition 1 (+)
2 Red/White	Battery 1 - 12V (+)
3 Green	Ignition 2 (+)
4 Purple	Accessory (+)
5 Red	Battery 2 - 12V (+)
6 Yellow	Starter Output

4 Pin Main Harness, Light, Siren, & Ground # 1124301

1 Black	Chassis Ground
2 White/Red	Parking Light Relay Input
3 White/Black	(+) Siren Output
4 White	Parking Light Relay Output

This Remote Start/Alarm System is designed to be used with Automatic Transmission- Fuel Injection Gas or Diesel Vehicles Only!

INSTALLATION OF THE MAJOR COMPONENTS:

CONTROL MODULE: PART # 1365527

Select a mounting location inside the passenger compartment (up behind the dashboard). The mounting location selected must be within 24" of the ignition switch wiring harness to allow connection of the 6 pin main wiring harness. Be certain that the chosen location will not interfere with proper operation of the vehicle. Avoid mounting the module to or routing the wiring around the steering shaft/column, as the module or wiring may wrap around or block the steering wheel preventing proper control of the vehicle. The module will be secured after all wiring is completed which will allow complete access until the job is done.

DO NOT Mount The Module In The Engine Compartment, as it is not waterproof.

HOOD PIN SWITCH: PART # 1363699

The pin switch included in this package is intended for protecting the hood area of the vehicle. In all cases, the switch must be mounted to a grounded metal surface. When the pin switch is activated, (hood open), it will supply a ground to the input wire activating the alarm. In addition, the hood switch is required for the safety shut down of the remote start unit. If the vehicle is being worked on, this hood switch prevents the remote start activation even if the RF command to start is issued. **This switch must be installed in all applications. Failure to do so may result in personal injury or property damage.**

THE PUSH-BUTTON/PROGRAM SWITCH/LED ASSEMBLY: PART # PRLED

Select a mounting location known and accessible to the operator of the vehicle. A dash knockout plug or front dash panel is desirable as the Push-Button LED assembly needs the LED to be visible from the outside of the vehicle and will be used for valet modes, programming features, programming transmitters, and for overriding the remote start unit when the vehicle is being serviced. Inspect behind the chosen location to insure that adequate clearance is allowed for the body of the switch, and also that the drill will not penetrate any existing factory wiring or fluid lines. Drill a 5/16" or 8mm hole in the desired location and mount the switch by passing the connectors, one at a time, through the panel from the front side and pressing on the bezel until the switch is fully seated. Note, when using the optional RF kit this switch will be used for feature and function programming

SHOCK SENSOR: PART # AS9492a

Select a centrally located, solid mounting surface for the shock sensor that will allow consistent operation from all areas of the vehicle. The selected location must be within 18" of the control module to allow routing and connecting of the 4 pin harness. Secure the shock sensor to the chosen location using two #8 self tapping sheet metal screws. The sensor can also be secured to an existing dash brace using cable tie straps. Whichever mounting method is used be sure to allow access to the sensitivity adjustment potentiometer for use later in the installation.

STARTER INHIBIT RELAY: PART # 1363731

Select a mounting location within 12" of the ignition switch's low current start solenoid wire. Secure the relay to an existing harness in the chosen location using a cable tie around the relay's wiring harness. **CAUTION!** Do not wire tie the metal bracket to an existing wiring harness as vibration may cause chaffing and shorting damaging the factory wiring. If an existing harness is not available then secure the relay's metal mounting tab to an under dash metal brace with a #8 self tapping sheet metal screw. Wire the relay as per the diagram found later in this manual.

This unit is to be used in vehicles with **AUTOMATIC TRANSMISSIONS** only! Although this combination Alarm/Remote Start unit is a sophisticated system with many advanced features, **IT MUST NOT** be installed into a vehicle with a **manually operated transmission**. Doing so may result in serious personal injury and property damage.

THE OPTIONAL TRANSMITTER / RECEIVER KIT AVXDATA:

The optional Transmitter / Receiver Kit , AVXDATA, allows you to combine any "E" series transmitter receiver combination and connect them via the AVXDATA to the AS9234E. You can then route the glass mounted receiver with LED and transmitter/programming switch to the AVXDATA, below the dash board for maximum operating range. Choose a mounting location for the receiver above the belt line (dashboard) of the vehicle for best reception. Special considerations must be made for windshield glass as some newer vehicles utilize a metallic shielded window glass that will inhibit or restrict RF reception. In these vehicles, route the antenna toward a rear window location for best reception. Secure the antenna with double stick tape provided in your kit. After securing the antenna with tape, we advise also securing a section of the antenna cable to a fixed support. This will prevent the antenna from dropping down in case the double stick tape is exposed to extreme heat which may loosen it's gummed surface. The AVXDATA module is installed between the receiver and the AS9234E. The PRLed will be used for feature programming and selection, and the push button on the windshield receiver will be used for transmitter programming.

IMPORTANT!

DO NOT PLUG THE SIX PIN MAIN POWER HARNESS OR THE MULTI PIN INPUT / OUTPUT HARNESS INTO THE CONTROL MODULE UNTIL ALL CONNECTIONS TO THE VEHICLE HAVE BEEN MADE. AFTER SELECTING YOUR TARGET WIRES AS DEFINED BELOW, DISCONNECT THE NEGATIVE BATTERY CABLE FROM THE VEHICLE BATTERY PRIOR TO MAKING ANY CONNECTIONS.

WIRING THE 6 PIN MAIN POWER HARNESS:

PART # 1123742

Note: Do not remove the fuse holders from this wire harness. Fuses must be used and located as close as possible to the power source for adequate protection of the vehicle.

1 BLUE Wire: Ignition 1 Output

Connect this wire to the ignition 1 wire from the ignition switch. This wire will show +12 volts when the ignition key is turned to the "ON" or "RUN" and the "START" or CRANK" positions, and will have 0 volts when the key is turned to the "OFF" and "ACCESSORY" positions.

For Diesel Applications, this wire must be connected to the ignition circuit that powers the glow plugs if the vehicle requires glow plug pre-heating. (See selectable feature Bank 3 #12)

2 Fused RED/WHITE WIRE: + 12 Volt Battery 1 Source

Locate the vehicle battery wire(s) at the ignition switch. Verification: These wires will register voltage in all positions of the ignition switch. Connect the Red w/White wire to the vehicle's battery wire. This wire provides power for the control circuit as well as the ignition 1 and ignition 2 relays.

3 GREEN Wire: Ignition 2 Output

Connect this wire to the ignition 2 wire from the ignition switch. This wire will show + 12 volts when the ignition key is turned to the "ON" or "RUN" position and in some cases the "START" or CRANK" position. This wire will show 0 volts when the key is turned to the "OFF" and "ACCESSORY" positions.

NOTE: See programming information (Bank 3 Selection #7) concerning this wire to allow output during the "START" mode.

4 VIOLET Wire: Accessory Output

Connect this wire to the Accessory wire from the ignition switch. This wire will show + 12 volts when the ignition switch is turned to the "ACCESSORY" or "ON" and "RUN" positions, and will show 0 volts when the key is turned to the "OFF" and "START" or "CRANK" positions. See programming information Bank 3 Feature # 9 for other optional settings of this output.

5 Fused RED WIRE: + 12 Volt Battery 2 Source

Locate the vehicle battery wire(s) at the ignition switch. Verification: These wires will register voltage in all positions of the ignition switch. Connect the Red wire to the vehicle's battery wire. This wire provides power for the start and the accessory relays.

6 YELLOW Wire: Starter Output

Careful consideration for the connection of this wire must be made to prevent the vehicle from starting while in gear. Understanding the difference between a mechanical and an electrical Neutral Start Switch will allow you to properly identify the circuit and select the correct installation method. In addition you will realize why the connection of the safety wire is required for all mechanical switch configurations.

Failure to make this connection properly can result in personal injury and property damage.

In all installations it is the responsibility of the installing technician to test the remote start unit and ensure that the vehicle cannot start via RF control in any gear selection other than park or neutral.

In both mechanical and electrical neutral start switch configurations, the connection of the Yellow wire will be made to the low current start solenoid wire of the ignition switch harness. This wire will have +12 volts when the ignition switch is turned to the start (crank) position only. This wire will have 0 volts in all other ignition switch positions.

NOTE: This wire must be connected to the vehicle side of the starter cut relay (when used). For the electrical neutral switch configuration, this connection must be made between the starter inhibit relay, (when used) and the neutral safety switch as shown in the following diagram.

Failure to connect this wire to the ignition switch side of the of the neutral safety switch can result in personal injury and property damage.

SEE NEUTRAL START SAFETY TEST FOR FURTHER DETAILS.

YELLOW START WIRE DETAIL

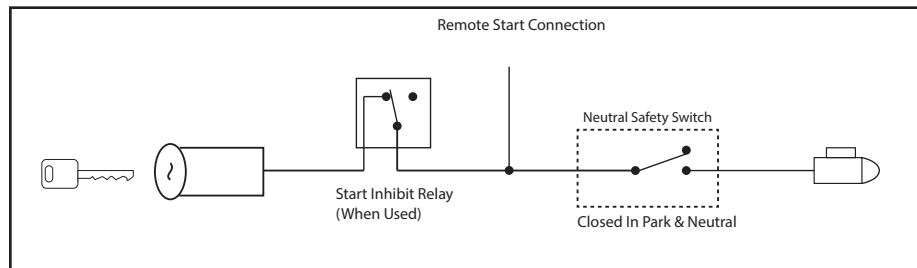

WIRING CONNECTIONS: 22 Pin Accessory Input/Output Harness**PART # 1124343****1 Orange Wire: 300mA (-) Ground When Armed Output**

This wire provides a 300 mA ground output when the alarm circuit is armed to control the starter inhibit relay. Connect the Orange wire to terminal #86 (orange wire) of the relay provided. Connect terminal #85 (red wire) of the relay to an ignition wire in the vehicle that is +12 volts when the ignition switch is turned to the on and start positions and off when the key is off. Locate and cut the low current start solenoid wire found at the vehicles ignition switch harness. This wire will have + 12 volts when the ignition key is moved to the start (crank) position and will have 0 volts in all other key positions. Connect one side of the cut wire to terminal #87a (Black wire) of the relay. Connect the other side of the cut wire to terminal #30 (White/Black wire) of the relay. See below for detail of wiring, also see Yellow Start wire detail for connection to vehicle considerations.

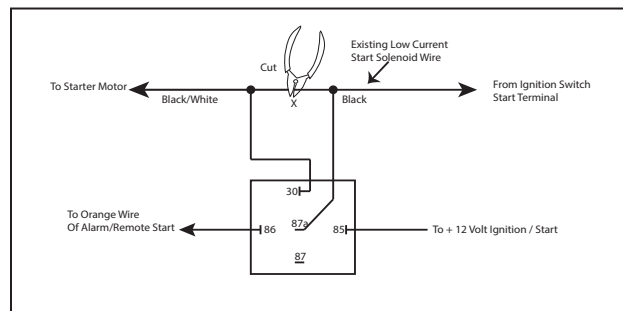
**2 Green/Yellow Wire: Diesel Wait To Start Input**

The green/yellow wire, when connected to the wire that get + 12 volts during the glow plug preheat stage will delay the starter output until this wire drops the 12 volts. In other words, in a Diesel vehicle with glow plug preheat circuit, when the ignition is turned on, the vehicle will not crank until the glow plugs are hot enough to fire the atomized fuel oil when injected into the cylinder. By connecting this wire to the glow plug + 12 volt wire, when the remote start unit activates the ignition one output, the glow plug output also activates. The remote start sees the green/yellow with positive voltage and waits for this to go inactive(drop the 12 volts) before activating the starter motor. If this wire is not used or you have difficulty accessing the glow plug preheat circuit, you may elect to utilize the Diesel timed output as specified in Remote Start feature selection bank 3 feature #12. NOTE: If green/yellow is used, it will override or negate any setting of feature #12.

3 Dark Blue/Black Trace Wire: External Trigger Input

The Dark Blue/Black trace wire allows the remote start unit to be activated from an external source. The intent of this wire is to allow the unit to be controlled from a "POSSE/CAR-LINK" paging system or similar device. When this wire receives a ground pulse, the unit will start the vehicle. Connect this wire to a ground pulsed output from the external controlling circuit.

4 Grey Wire: Negative Inhibit Input / Trigger When Armed

The Grey wire prevents remote starting and provides an instantaneous shutdown for the Remote Start Control Module whenever it is grounded. This wire also trigger the alarm when armed. Connect the Grey wire to the hood pin switch previously installed. This wire must be routed through a grommet in the firewall and connected to the hood pin switch. If connecting to a factory hood pin switch, it is recommended that a double diode circuit be used to prevent feed back of one device to the other.

IMPORTANT! This connection is a safety wire and must be connected as shown and tested as specified.

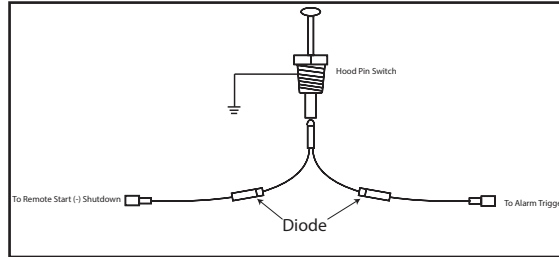

Failure to do so may result in personal injury or property damage. See detail of wiring in the following diagram. This wire may also be used if the vehicle brake light circuit switches ground to the brake lights. An isolation diode must be used for ground switched brake light circuits and must be connected to the output of the brake switch.

5 Brown w/ Black Trace Wire: Positive Inhibit Input Plus Trigger When Armed

The Brown w/ Black Trace wire prevents remote starting and provides an instantaneous shutdown for the Remote Start Control module whenever it gets + 12 volts and triggers the alarm when armed. If the Brake lights switch in the vehicle switches + 12 volts to the brake light circuit, connect the Brown w/ Black trace wire to the output side of the brake switch. This will allow the Remote Start to shut down if an attempt is made to operate the vehicle without the key while running under the control of the Remote Start. In most vehicles, in order to shift into gear, the brake pedal must be depressed. The brake input will in turn cause the remote start unit to shut off.

6 NC: No Connection, Empty Cavity

GREEN/BLACK, RED, GREEN, RED/BLACK, & BLUE Factory Keyless Inputs.

The Green/Black input wire # 19, Red input wire # 18, Green input wire # 7, and Red/Black input wire # 17 are polarity learning inputs which will be connected to the vehicle lock & unlock 1, and lock & unlock 2 control wires. When the control circuit is first powered up, these wires will learn the resting state of the circuits they are connected to.

DO NOT operate the vehicle's door lock circuits, (switch or remote), while power is being applied to this upgrade alarm system or the unit will not operate properly. Also if these wires are not being used, as in the case of DBI control, they MUST be connected to ground to insure proper operation of the circuit.

UNDERSTANDING ARM & DISARM #1 AND #2:

Because of the complexities of the different factory installed Remote Keyless Entry Units on the market today, this system uses two disarm and two arm inputs. Whether installing into a vehicle using a 2-step unlock circuit, single step unlock circuit, or as a stand alone passive alarm, both disarm and arm wires must be connected in all installations. The arm and disarm functions of this system are learned during power up, by monitoring the resting state of the factory wires when power is applied to the unit. Be certain all wires are connected to the vehicle before applying power to the circuit to insure the system responds only during operation from the factory transmitters. These inputs can be configured in an AND or OR configuration and is explained in more detail under feature selection Bank 2.

7 Green Wire : Arm Input #1

Connect this wire to the lock side of the door lock/unlock switch or, the driver's door lock motor leg wire, which will receive a negative or positive pulse when the doors are locked using the door switch or the remote transmitter.

8 Yellow w/ Black Trace Wire: + 12 Volt Alarm By - Pass Output

NOTE: You must disconnect the ignition input of the alarm from any other wire that it is presently connected to in the vehicle.

This wire provides a + 12 Volt output when the ignition key is turned to the "ON" position, and 0 Volts when the ignition key is "OFF" and when the vehicle is running under the control of the remote starter. This wire should be connected to the ignition input of the factory or after market alarm system. The Yellow w/ Black wire output will allow you to remote start the vehicle while leaving the factory or after market alarm armed, and to lock & unlock the doors while running under control of the remote start unit.

9 Black w/ Red Trace Wire: Pulsed Ground Output After Shutdown

The Black w/ Red Trace wire's 300mA output is selectable for a number of different options as shown in feature bank 3 option 22. The default setting is for pulse after shut down and as such will provide a 1 second 300 mA pulsed ground output 2 seconds after the remote start's Light Blue GWR output shuts down. This output will occur regardless of whether the circuit times out or is manually terminated. Typically this output will be used to re-lock the vehicle doors if the doors unlock automatically when the ignition circuit transitions to off. Other settings are shown in the selectable feature settings menu list Bank 3 Option 22.

10 Black w Blue Trace Wire: Pulsed Ground Output Before Start

The Black w/ Blue Trace wire's 300mA output is selectable for a number of different options as shown in feature bank 3 option 19. The default setting is for a 1 second pulsed ground output 1.5 second before the remote start unit activates as well as when the transmitter is used to disarm the system. Typical use for this output would be to disarm a factory theft deterrent system to prevent false triggering of the factory alarm when the remote start unit engages and can be used to unlock the doors via the transmitter while under control of the remote start unit.

NOTE: This output's timing can be selected to operate like the door lock output as set in alarm feature setting #1 or selected to work at various different pulse output timings by selecting feature #19 in Bank 3. When selected for 2 Chirps the output would mimic bank 2 feature 1, otherwise other setting are self explanatory as listed in the feature setting menu list Bank 3 Option 19.

11 Black w/ Yellow Trace Wire: Ground Output During Start (Crank)

The Black w/ Yellow Trace wire's 300mA output is selectable for a number of different options as shown in feature bank 3 option 20. The default setting is as a ground output while the starter output of the remote start unit is active. This output can be used to activate the Crank Low/Bulb Test wire found in some GM vehicles. This wire is also referred to as the ECM wake up wire in some vehicles. Other settings are shown in the selectable feature settings menu list Bank 3 Option 20.

12 Green w/ Orange Trace Wire: Tachometer Input Signal

This wire will continually monitor the engine's tach rate while the unit is under power of the Remote Start module. This wire will be routed to the vehicle ECM tach input or through the firewall into the engine compartment and connect to the negative side of the ignition coil. This Remote Start unit learns the tach rate of the vehicle and in most cases will operate properly from one multi coil pack regardless of the number of cylinders. If the vehicle has a single coil unit for each cylinder, it may be necessary to connect this wire to more than one cylinder for proper tach reference. If using multiple coils, see Multi Coil Pack Adapter wiring detail shown later in this manual for additional information. This wire may also be connected to a fuel injector for a tach reference.

Note: For Voltage Sense, Hybrid Mode, and DBI selections, this connection may not be used see Bank 3 feature selection #5, the unit will start the vehicle and run the allotted time based on feature selection. If selection of other longer crank time is required please see bank 3 feature 11. When using Voltage

mode or Hybrid mode please insure feature 14 is set for 1 Chirp, Averaging. This will insure that the unit constantly adjusts the crank time based on the operators use of the ignition key. Also when selecting crank averaging, the vehicle must be started manually 4 or 5 times to initiate a start reference point.

13 Dark Green Wire: (-) Instant Trigger Input

The Dark Green wire is the instant on ground trigger input wire. This wire must be connected to the hood pin switch previously installed, and can be connected to the trunk pin switch where used.

NOTE: This wire will be shunted when remote control channel 3 is accessed, (trunk release). This wire will remain shunted all the while there is ground present and for 5 seconds after the ground is removed. This allows the operator to open the trunk via the remote transmitter without having to first disarm the alarm system.

14 Brown Wire: (-) Negative Door Trigger

If the vehicle's door courtesy light switches ground when the door is opened, (Most GMs and Imports), you must connect this wire to the negative output from one of the vehicle's door pin switches. In most cases the Brown wire will need to be connected to only one door switch no matter how many doors the vehicle has as most door lighting circuits are wired in parallel. This wire will be shunted when remote starting the vehicle and will remain shunted, if active, while running under command of the remote start. If this wire is active when the system is armed, the siren will emit three chirps. When the zone clears, the siren will emit 1 chirp to confirm full arming.

Note: for vehicles with interior delay lighting see programming under title "Completing The Installation".

15 Purple Wire: (+) Door Trigger Input

If the vehicle's door courtesy light switches + 12 volts when the door is opened, (Some Fords and some Imports), you must connect this wire to the positive output from one of the vehicle's door pin switches. In most cases, the Purple wire will need to be connected to only one door switch no matter how many doors the vehicle has as most door lighting circuits are wired in parallel. This wire will be shunted when remote starting the vehicle and will remain shunted, if active, while running under command of the remote start. If this wire is active when the system is armed, the siren will emit three chirps. When the zone clears, the siren will emit 1 chirp to confirm full arming.

Note: for vehicles with interior delay lighting see programming under title "Completing The Installation".

16 Blue Wire : Trunk Trigger Shunt Input (+)

This wire will determine if the vehicle's trunk has been opened using the OEM transmitter, and prevent the alarm from triggering when the factory transmitter is used. This wire requires a positive trigger input and must be wired to the switched + 12 volt trunk control wire from the vehicle's keyless entry unit or, the switched + 12 volt side of the vehicle's trunk release solenoid. When the system is armed, and this input gets 12 volts, the all trigger inputs are inhibited and remains inhibited for an additional 5 seconds after the trunk zone clears.

NOTE: These wires, Green/Black #19, Red #18, Green #7, & Red/Black #17 **MUST** be connected to their respective source before powering up the module as these wire are polarity learn and will not function properly if connected after power up. In addition, these wires, **if not physically wired to the vehicle doors as indicated, must be connected to ground**, to will proper operation and prevent inadvertent arming and disarming unintentionally. This includes using DBI source for Arm/Locking, & Disarm/Unlocking. These inputs can be configured in an AND or OR configuration and is explained in more detail on page 26 & under feature selection Bank 2.

17 Red w/Black Trace Wire : Disarm Input #2

Connect this wire to the unlock side of the door lock/unlock switch or any passenger door unlock motor wire, which will receive a negative or positive pulse when all doors are unlocked using the door panel

switch or the remote transmitter, **but will NOT receive a pulse when the driver only door is unlocked using the remote transmitter.**

18 Red Wire : Disarm Input #1

Connect this wire to the driver's door unlock motor wire, which will receive a negative or positive pulse when the drivers door is unlocked with the remote transmitter, and the door switch, but does not receive a pulse when all doors are unlocked using the remote transmitter.

19 Green/Black Wire : Arm Input #2

Connect this wire to the vehicles door lock switch input wire, which will receive either a switched positive or switched negative when the door lock switch is moved to the lock position. This wire will be used to compare the two inputs Arm #1 & Arm #2. If both inputs are active at the same time, in the AND configuration, the vehicle will not arm. The intent of this wire is to prevent the system from arming when the in vehicle door lock switch is used to lock the doors, insuring only the transmitter arms the system. If you do not desire this feature or the customer prefers that the door lock switch arm the system as well as the transmitter, connect this wire to chassis ground.

20 Black w/ White Trace Wire : 300 mA Horn Output

The black w/ white trace wire is provided to beep the vehicle's horn. This is a transistorized low current output, and should only be connected to the low current ground output from the vehicle's horn switch. If the vehicle uses a + 12 VDC horn switch, then connect the black w/ white trace wire to terminal 86 of the AS 9256 relay (or an equivalent 30 Amp automotive relay), and connect relay terminal 85 to a fused + 12 VDC battery source. Connect relay terminal 87 to the vehicle's horn switch output, and connect relay terminal 30 to a fused + 12 VDC battery source.

21 Light Blue Wire: Ground Output While Running (-) 300mA

This wire provides a 300mA ground output that becomes active 1 seconds after the pulse before start and 1 second before ignition 1 activates and remains grounded while running plus an additional 2 seconds after the Remote Start Unit turns off. In all of the applications described below, a relay will be required.

The Light Blue wire can be used to accommodate the following situations:

A. Sensor By Pass:

If there is a Non Plug in Sensor used with the alarm system and it is not shunted during the Remote Start activation period, then vibration or noise from the running vehicle can cause the alarm to trigger. In this case, connect the Light Blue Wire to terminal #86 of a external relay. Connect terminal # 85 of the relay to a fused + 12 volt battery source. Cut the sensor's trigger wire and connect one end of the cut wire to terminal #30 and the other end of the cut wire to terminal #87a. Just before the Remote Start unit is activated, the relay contacts will open, preventing the sensor's operation until the Remote Start unit shuts off.

B. Additional Ignition Output:

Some vehicle's may require more than three ignition outputs to start and keep the vehicle's engine running. If this is the case, connect the Light Blue wire to terminal #86 of an external relay. Connect terminal # 85 to a fused + 12 volt source. Dependent on the vehicle's requirement, connect terminal #30, to a fused + 12 volt source, or to ground, and connect terminal 87 to the vehicle to supply the additional ignition source.

C. GM VATS Key Override:

If the vehicle has the General Motors VATS system installed, you will need to bypass the system while the vehicle is operating under the control of the Remote Start Unit. To Do This:

1. Measure the resistance of the resistor pellet on the ignition key then select a resistor within 5% of the key's value from the resistor pack supplied.
2. Locate the pair of VATS wires in the vehicle, usually a pair of thin gauge wires running from the ignition switch to the VATS control module.

NOTE: These wires are typically White w/ Black trace and Violet w/ Yellow trace, however in later model Cadillacs, they are run through an orange sleeve, and are either both Black, both Yellow, or both White wires. Consult the factory service manual for additional information.

3. Connect the Light Blue Wire from the Remote Start Unit to terminal #86 of an external relay. Connect terminal #85 of the relay to a fused + 12 volt battery source.
4. Cut (#1) wire (as shown), and connect the ignition switch side of the cut wire to terminal #87a of the relay. Connect the other side of the (#1) wire to terminal #30.
5. Connect the previously selected resistor from terminal #87 to the second (#2) wire (as shown).

NOTE: The above information and following diagram is for the GM VATS system only.

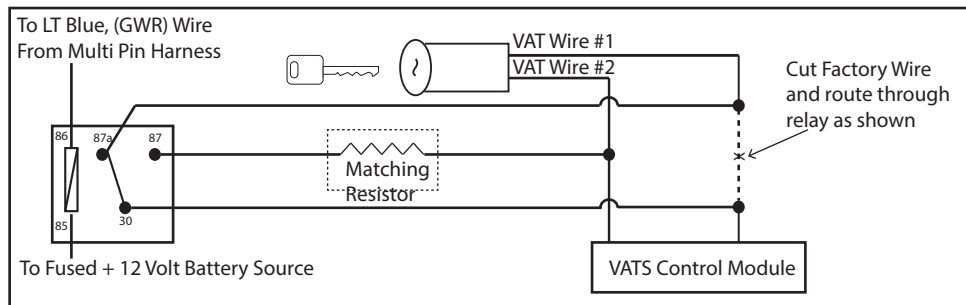

D. Anti-Grind Starter Circuit Connection:

This wire, when connected to a starter inhibit relay, as shown in the diagram below, will prevent the customer from engaging the starter while the vehicle is running under control of the remote start.

Configured in this way, while the remote start is controlling the vehicle, the light blue wire has ground on it all the time. This ground will cause the relay to energize preventing current flow through the normally closed contacts. This will prevent a customer who inadvertently turns the ignition switch to the start position, from sending current to the starter.

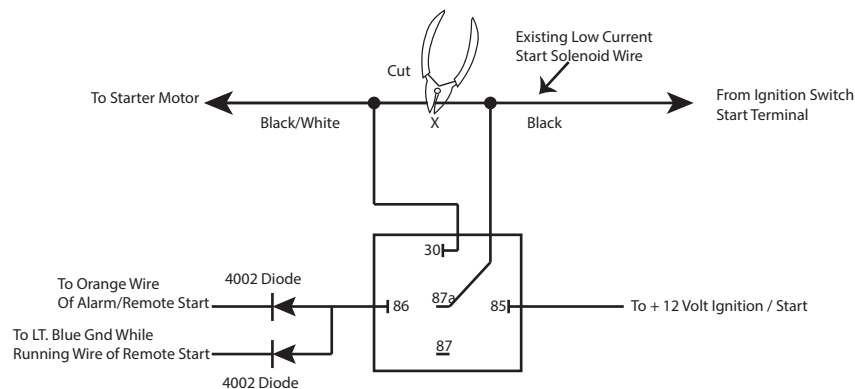

E. FlashLogic By-Pass Enable Output / Ground While Running:

This wire when connected to our Flash-Logic module GWR input will control the turning on of the By-Pass module and insure it is synchronized with the Remote Start for seamless integration.

22 Black w/ Light Green Trace Wire: Pulsed Ground Output After Start

The Black w/ Light Green Trace wire will provide a 1 second 300mA pulsed ground output after the vehicle is started under control of the remote start unit. Typically this wire will be used to re-lock the vehicle doors if the doors unlock automatically when the factory anti-theft system is disarmed. This wire will also activate when the transmitter is used to arm the system/lock the vehicle. Other settings are shown in the selectable feature settings menu list Bank 3 Option 21.

4 Pin Main Harness, Light, Siren, & Ground # 1124301

1 Black Wire: Chassis Ground Source

Connect the Black wire to a known vehicle ground source or to a solid clean metal part of the chassis. Be certain to remove any paint or grease and secure this wire with a self tapping screw and ring terminal.

2 White w/ Red Trace Wire: Parking Light Flasher Input

This wire is the common contact of the on board parking light flasher relay. If the vehicle you are working on has +12 volt switched parking lights, connect this wire to a **FUSED** + 12 volt source. (Max. 15 Amps) **NOTE:** If the vehicle's parking lights are ground switched, connect this wire to chassis ground.

3 White w/ Black Trace Wire: (+) Optional Siren Output

This is the positive siren feed wire. Route this wire through a grommet in the firewall to the siren location. Connect the White w/ Black Trace wire to the Red wire of the Siren. Secure the Black wire of the Siren to a known chassis ground or solid clean metal surface.

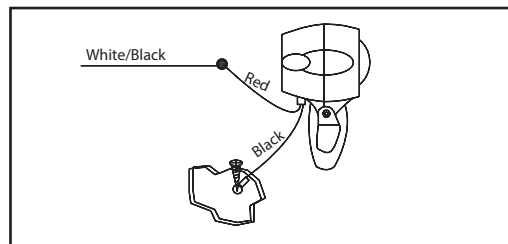

4 White Wire: Parking Light Flasher Output

This wire is the normally open contact of the on board parking light flash relay. Connect this wire to the vehicle's parking light feed wire. This is the wire that gets switched on, either (+) or (-), when the vehicle's parking light switch is activated

Parking Light Wiring Detail

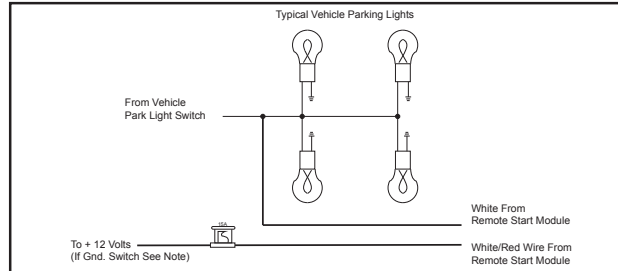

2 Pin Door Lock/Unlock Harness: (White Connector) 300mA

Part # 112242

1 Red Wire: (-) Lock

The Red wire provides a (-) Negative Pulse when locking.

2 Green: (-) Unlock

The Green wire provides a (-) Negative Pulse when unlocking

3 Wire Ground Switched Door Lock Circuits:

In this application, the Red wire of the door lock harness provides a ground pulse during the arming sequence, or pulsed ground lock output. Connect the Red wire to the low current ground signal wire from the factory door lock switch to the factory door lock relay.

The Green wire of the door lock harness provides a ground pulse during the disarming sequence, or pulsed ground unlock output. Connect the Green wire to the low current ground signal wire from the factory door unlock switch to the factory door unlock relay. See the following diagram for Wiring Detail.

3 Wire Ground Switched Door Lock/Unlock Wiring Detail

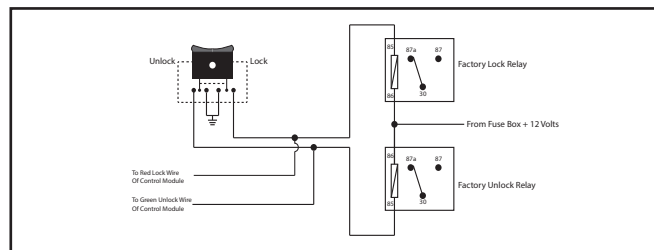

3 Wire Positive Switched Door Locks:

For three wire positive door lock circuits, you will have to invert the output of the door lock wires, with relays or with the "DLVI" Door Lock Voltage Inverter. The DLVI converts a negative pulse to a 1A positive pulse. When using the DLVI, cut the 3 Pin Green & Blue Connector, and splice the Blue from the DLVI to the Green Door unlock wire of the module's door lock harness. Splice the Green of the DLVI to the Red Door Lock Wire of the module's door lock harness. Connect the Red From the DLVI to a fused 12 Volt Source. Connect the Blue (+) Unlock control output from the DLVI to the vehicles low current (+) Door Unlock Wire. Connect the Green (+) Lock control output from the DLVI to the vehicles low current (+) Door Lock Wire. See Below For Wiring Detail.

3 Wire Positive Switched Door Lock/Unlock Wiring Detail

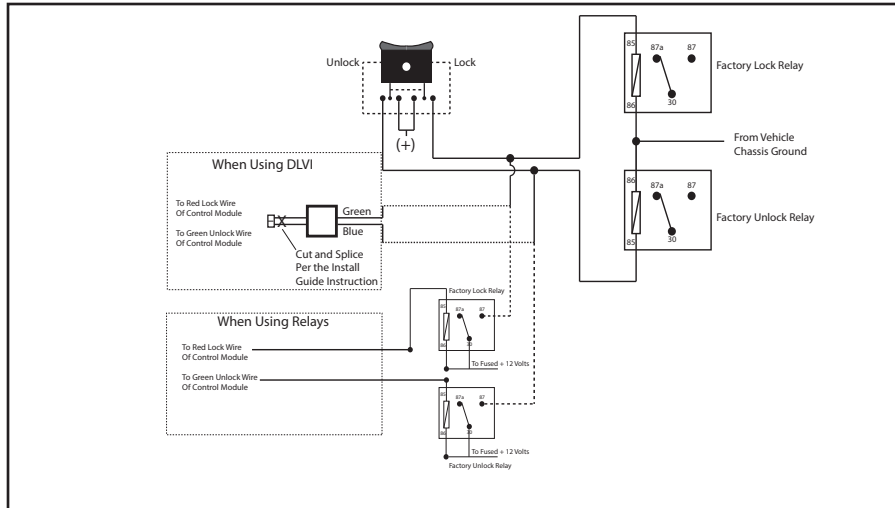

NOTE: 4 Wire Polarity Reversal and 5 Wire Alternating 12 Volt Door Lock Control Circuits As Well As Resistive Circuits, Multiplex Circuits

These applications require the use of additional components which may include relays, fixed resistors, or for convenience, a Door Lock Interface. Some of these circuits are shown following this text and is for visual reference only. Refer to your specific vehicle door lock arrangement and wiring for more detailed/specific information.

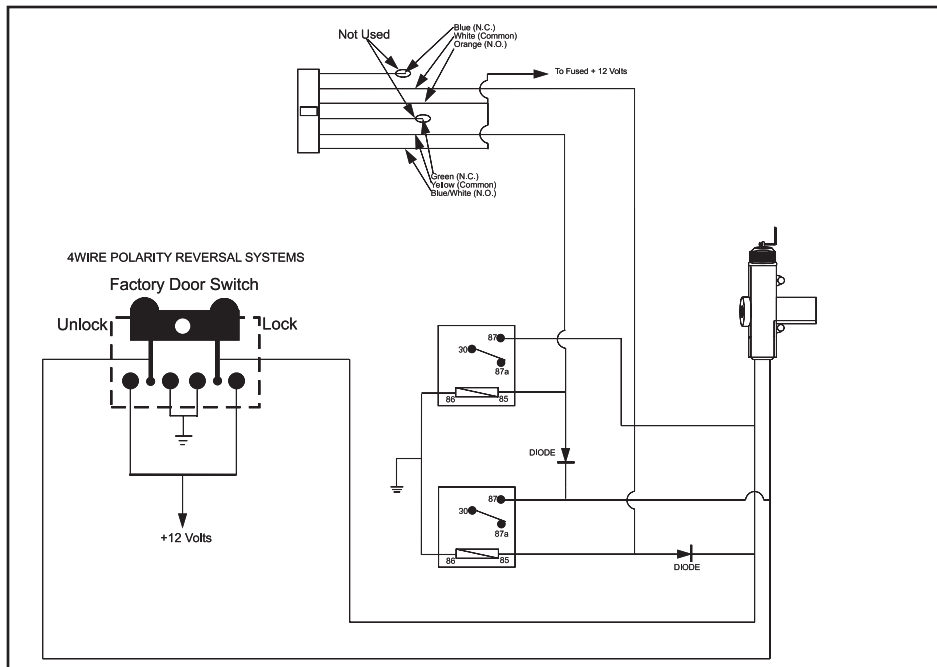

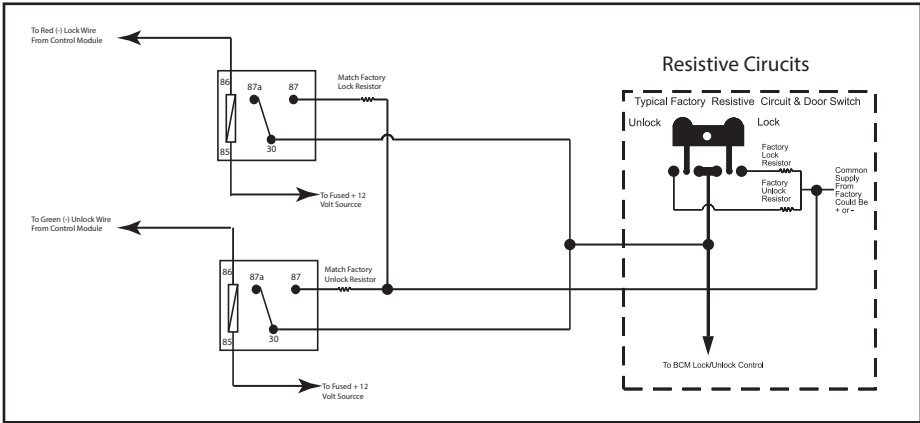
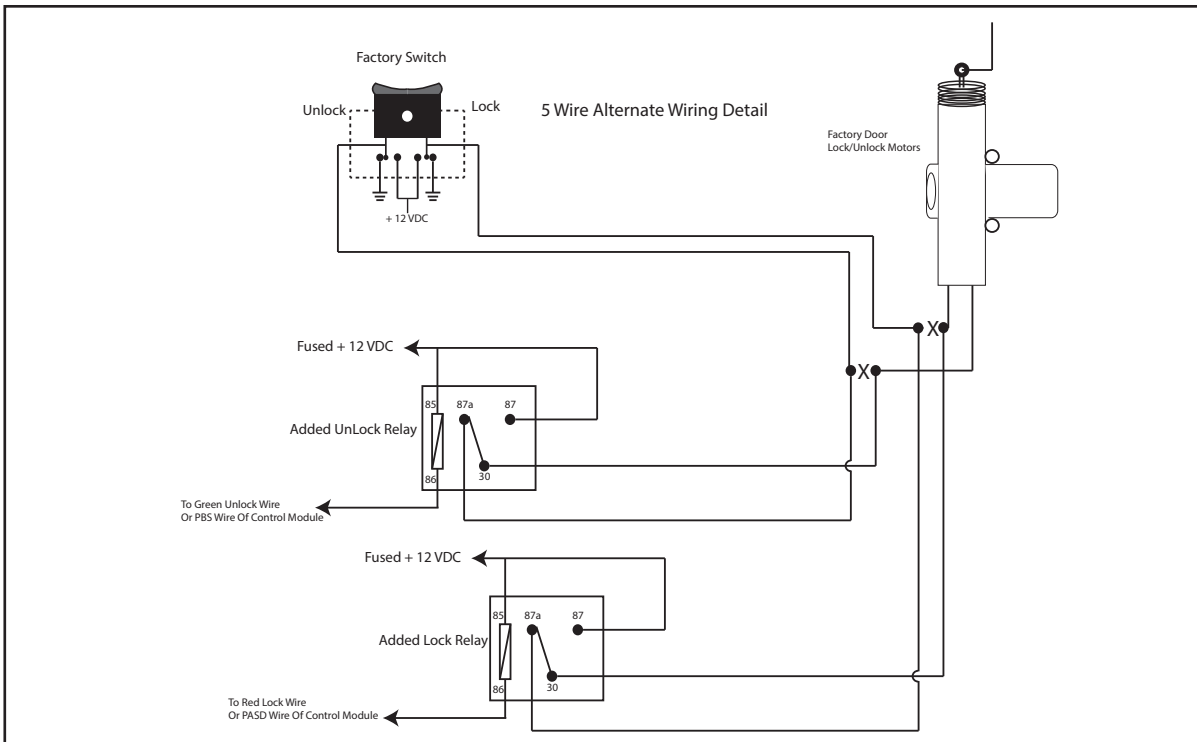

Additional Harnesses And Connectors For The System

4 Pin Upgrade Telematic Module: (Connector Port)

Red = + 5 Volts / Black = Ground / White = Data TX / Yellow = Data RX

Connect the 4 pin harness found in the Car Connection Telematic kit to the mating port on the AS9234E
 NOTE: If using earlier TWO WAY Telematic module, only Ground, TX, and RX are used on this port, the + 12 volt supply for the two way module must be sourced separately or the unit will not operate.

Optional Receiver Program Push-Button Switch/LED Connector: Part #'s AVXDATA

The AVXDATA kit allows the connection of a number of Receivers and Transmitter combinations to be connected to and to operate the AS9234E. These kits will plug into the module's AVXDATA port and when connected with the respective receiver will allow programming of the transmitters. The feature and other function will use the PRLD for programming and selection. Please follow the instructions packaged with the specific AVXDATA kit you are installing.

4 Pin Shock Sensor: (White Connector) Part # 1122591

The Red (+12 volt), Black (ground), Blue (pre-detect) and Green (full trigger when armed) wires loaded into the white connector shell are the inputs/outputs of the shock sensor. Route the 4 wire harness from the shock sensor to the remote start control unit and plug the 4 pin white connector into the mating 4 pin connector shell of the control module.

NOTE: Bank 3 Feature15 allows the shock sensor to be set to shunt all the time with Remote Start, Shunt from the transmitter, or shunt only on initial start while there is vibration and re-instate once vibration settles down. Setting this properly will insure that there is no false triggers while remote starting the vehicle.

4 PIN IN VEHICLE DATA BUS PORT (DBI Port) (Connector Port)

The 4 pin port located on the side of this module is for proprietary Flash Logic data bus interface modules. These modules are used to access a variety of features in the vehicle which can be as simple as door trigger inputs, to more complex door locks outputs, or transponder interfaces for remote starting. DO NOT connect anything to this port other than the DBI modules or damage to the Remote Start module will occur. All installation instructions for the DBI modules will be packaged with the individual component along with the proper 4 pin wiring harness requires to access the data transmit & receive as well as the proper voltage levels for the interface.

TIMED START PROGRAM:

The Remote Start unit has the ability to start the vehicle automatically at timed intervals. This feature is useful in extremely cold climates where starting the engine is the only means to keep the battery charged and fluids warm. The operator has the option to have the unit start every 2 or 4 hours for a maximum of 48 hours. Factory preset is to start at 4 hour intervals. To select 2 or 4 hour automatic start timer:

1. Start By Holding the Push Button Switch found on the PRLD.
2. While Holding the Push Button Switch Turn The Ignition Switch On Then Off
- 3a) Within 10 seconds of turning the ignition switch off, Release and then Push On and release the Push Button Switch 2 times holding it on the second time until the siren and or lights flash and chirp 2 times indicating that the 2 Hour Start Interval has successfully been set. or
- 3b) Within 10 seconds of turning the ignition switch off, (Step 2) Release and then Push On and release the Push Button Switch 4 times holding it on the fourth time until the siren and or lights flash and chirp 4 times indicating that the 4 Hour Start Interval has successfully been set.

NOTE: Once selected, 2 or 4, this timer interval will remain in memory until it is manually changed. To change, the above sequence will have to be followed.

TIMED START OPERATION:

To begin the start timer, within 10 seconds of turning off the ignition switch, activate the RF command to start 2 times. (Press the start button four times). The lights will flash and the siren will chirp 4 times. Indicating timed interval mode has been initiated. The vehicle will automatically start every 2 or 4 hours as programmed. To cancel the timed start mode start the vehicle either by RF or by the ignition key.

DIESEL ENGINE SETTINGS:

NOTE: When selecting Diesel operation, (Bank 3 Feature #11), over gasoline, the only change is to the ignition circuits. When Diesel is selected, the ignition circuits will power up 10, 15, or 20 seconds before the start circuit. The intent of this feature is to allow the glow plug warming required by some diesel engines. If your vehicle is a instant start diesel, it is not necessary to activate this feature.

ALSO: When selecting Diesel mode, be certain that the intended vehicle has a true tach reference and be certain to connect the tach input wire. Also note, if the "Diesel Wait to Start" input is connected, (Green/Yellow) this wire will take precedence over the Diesel selection of bank 3 feature 11.

Monitoring The Vehicle's Engine:

(Program Bank 3 Feature # 5)

There are 4 ways that the remote start monitors the engine running, one or the other must be selected for your application for the remote start to operate correctly.

1) VOLTAGE SENSE SETTING:

The unit will monitor the voltage level of the battery during remote start, wait for the voltage to drop while cranking, then look for the voltage level to go above the level it was before the vehicle began to crank which indicates the vehicle is running. Feature #14 of Bank 3 must be set for averaging or the voltage sense feature will not operate indicated by the parking lights flashing 7 times.

2) TACH RATE SETTING:

1. Turn the ignition key to the On position.
2. Press and release the valet/program push button switch 3 times.
3. Immediately turn the ignition key Off.
4. Press and hold the valet/program push button switch, then start the vehicle using the key.
5. When the unit senses the tach signal, the parking lights will begin to flash.
6. Release the valet/program pushbutton switch. The parking lights will turn on for three seconds to indicate that the learned tach signal is stored and the unit is out of the tach learn mode.

NOTE: If the unit fails to learn tach rate due to an improper tachometer connection or a poor tach source, the parking lights will not flash. To correct this situation, locate and connect the Green/Orange wire to the proper tach signal, and then repeat the tach learn routine.

3) DBI TACH SETTING

Selecting this setting in the option menu indicates that you have a DBI module and have determined that a tach signal is available for the vehicle you are connecting to. The unit will look at the DBI data port for the tach signal. If the vehicle fails to start, or the unit flashes 7 times, recheck the DBI manual to insure that tach is available for your vehicle. If not the tach connection wire, Green/Orange must be used.

4) HYBRID SETTING:

Selecting this setting in the option menu allows for Hybrid vehicles. Also feature #14 of Bank 3 must be set for averaging or the Hybrid feature will not operate indicated by the parking lights flashing 7 times.

CRANK AVERAGING:

When Feature #14 Bank 3 is set for crank averaging, the remote start unit constantly monitors and learns the cranking patterns of the vehicle each time the car is started with the key. The vehicle must be started at least 4 times with the key for the crank averaging circuit to begin it's monitoring the vehicle's engine.

DIAGNOSTICS:

Enter Bank 3 and turn on selectable feature # 10 as described on the front pages of this manual.

NOTE: Diagnostic mode is a temporary mode. Once you have accessed the diagnostic mode, the unit will pause for two seconds then begin to flash the last stored shut down code. This code will be displayed three times in succession, then the unit will automatically exit the diagnostic on mode.

The parking lights will flash a number of times indicating the reason for the last remote start shutdown. The light flash indications are as follows:

1 Flash	Run timer expired
2 Flashes	Low or no tach signal (RPM)
3 Flashes	Positive inhibit wire activation
4 Flashes	NA
5 Flashes	RF shutdown, Remote signal received, or manual start trigger wire reactivated.
6 Flashes	High tach signal (RPM)
7 Flashes	Tach signal has not been learned
8 Flashes	Negative inhibit wire

Multi Coil Pack Adapter: (Optional)

The multi coil pack adapter, is designed for use with vehicles that do not respond to single coil tach programming. Although the tach resolution of this circuit is designed to interface direct with most vehicles, there may be an occasion where the following circuit may be required. Construct the adapter as shown below.

To use the adapter, the Green/Black wires must connect to the negative side of the ignition coil(s).

1. For vehicles utilizing independent coils per cylinder, connect the three Green/Black leads to alternate coils. To achieve optimum performance the coil signals must be evenly distributed. This is accomplished by first mapping out the firing order of the engine in groups of as indicated below. Draw a circle around any of the columns. The Green/Black wires should be connected to the negative (-) terminal of the respective cylinder number which appears in any of the circles.
2. For vehicles utilizing 2 cylinder firing per coil pack, connect Green/Black to the tach side of each coil pack. For 8 cylinder, four coil systems, connect to any of the three coils.
3. Connect the Yellow wire to a +12 volt ignition 1 source. This wire will have +12 volts with the ignition in the on and start position and have 0 volts with the ignition in the off position.
4. Connect the Green wire to the (Green) or (Orange/Green) tach input of the remote start unit.

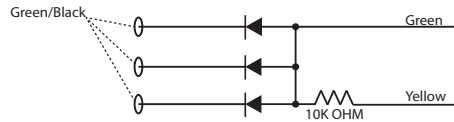

IF THE FIRING ORDER IS 1,8,4,3,6,5,7,2

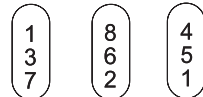

CONNECT TO CYLINDERS 137, OR 862, OR 451

IF THE FIRING ORDER IS 1,5,6,3,4,2,7,8

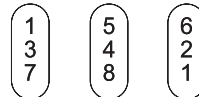

CONNECT TO CYLINDERS 1,3,7 OR 5,4,8 OR 6,2,1

TESTING YOUR INSTALLATION:

WARNING!! The following procedure must be performed after the installation of any Remote Start Device. It is the responsibility of the installing technician to complete these tests. Failure to test the unit in the following manner may result in personal injury, property damage, or both.

HOOD PIN SAFETY SHUT DOWN:

The intent of the hood pin safety shut down is to prevent the Remote Start unit from being activated while a mechanic or vehicle owner is performing normal routine vehicle maintenance.

To test the integrity of this circuit:

1. With the drivers window in the down position, start the vehicle using the RF transmitter.
2. Reach inside the car and pull the hood release.
3. Raise the hood and confirm that the remote start unit shuts down.

If the unit fails this test, recheck your pin switch connection to the Gray/Black wire of the Remote Start Unit.

DO NOT RELEASE THIS VEHICLE TO THE CONSUMER UNTIL YOU CONFIRM THE OPERATION OF THE HOOD PIN SAFETY SHUT DOWN FEATURE.

REMOTE START OVERRIDE MODE / MANUAL SHUT DOWN:

The intent of the remote start override / manual shut down circuit is to allow the vehicle operator to prevent operation of the Remote Start Unit regardless of the RF transmitter operation.

To Enter The Remote Start Override Mode:

- 1) With the system disarmed/unlocked, and the ignition switch off Press and Hold the pushbutton switch on.
- 2) Turn the ignition switch on, off, on, off, on, off.
- 3) The LED begins to flash two short flashes followed by one long flashes and continues this pattern until returned to normal mode of operation.
The action above puts the unit into the Remote Start Override mode or vehicle service mode and will not start from the RF transmitter or any other input.

To Exit Remote Start Override Mode:

- 1) With the system disarmed, Press and Hold the pushbutton switch on.
- 2) Turn the ignition switch on, off, on, off, on, off.
- 3) The LED turns off indicating that the R/S unit is fully functional one again.

DO NOT RELEASE THIS VEHICLE TO THE CONSUMER UNTIL YOU CONFIRM THE OPERATION OF THE MANUAL SHUT DOWN / ENABLE FEATURE.

NEUTRAL START SAFETY TEST:

The intent of the neutral start switch is to prevent the vehicle from starting while the gear selector is in any position other than Park, or Neutral. When installing a Remote Start Device, it is imperative that the Yellow Starter wire be connected to the ignition switch side of the Neutral Start Switch. Consideration for the placement of a starter inhibit relay is important as well and should be connected to the ignition

switch side of the Yellow Start Wire.

To test the integrity of the Neutral Start Safety Circuit:

- 1) Set the vehicle parking brake.
- 2) Block the drive wheels to prevent vehicle movement.
- 3) Temporarily disconnect the Brown/Black positive shut down wire from the vehicle's brake switch.
- 4) Sitting in the vehicle, start the engine using the vehicle's ignition key.
- 5) Step on the brake pedal and shift the gear selector into reverse.
- 6) Allow the transmission to shift. When you feel the engine pull, do not move the gear selector just turn the ignition switch off. DO NOT attempt to remove the key.
- 7) Keeping the brake pedal depressed, activate the RF transmitter in an attempt to start the vehicle. The car should not start.
- 8) Repeat the above test this time move the gear selector to the drive position.

If the unit attempts to start, failing this test, recheck your Yellow Wire's connection. This wire must be connected to the ignition switch side of the Neutral Start Switch. If the vehicle you are working on does not have an Electrical Neutral Safety Switch, it will be necessary to reconfigure the Remote Starts Wiring to accommodate the vehicle. The information concerning the Mechanical Neutral Safety Switch provided below will help you to determine if the vehicle you are working on has this type of safety switch and will provide alternate wiring methods to accommodate this situation.

CAUTION! REMEMBER TO RECONNECT THE BROWN/BLACK NEUTRAL SAFETY WIRE TEMPORARILY DISCONNECTED IN STEP 3

MECHANICAL NEUTRAL SAFETY SWITCH CONSIDERATIONS:

Mechanical neutral safety switch configurations differ slightly in that they do not offer the same level of safety when installing a remote start device. Often when the ignition switch is turned off while the gear selector is in any position other than park or neutral, the mechanical function will not allow the key to be turned to the start position or be removed from the ignition cylinder. This configuration prevents mechanical operation while the vehicle is in gear but offers no consideration for electrical operation. Because of this potential problem, this installation requires the additional connection of a safety wire from the remote start device to the vehicle Park/Neutral ECM Input or the vehicle key in sensor. This connection will prevent remote start operation if the key is left in the ignition switch regardless of the gear selectors position.

DO NOT RELEASE THIS VEHICLE TO THE CONSUMER UNTIL YOU CONFIRM THE OPERATION OF THE MECHANICAL NEUTRAL SAFETY START FEATURE.

KEY IN SENSOR CIRCUITS:

If the vehicle you are working on does not have or you cannot locate the ECM reference wire, there are two alternatives available. Although not preferred, the vehicle Key In Sensor may be reconfigured to allow a margin of safety and will prevent the vehicle with a Mechanical Neutral Start Switch from starting in gear.

VOXX ADVISES THAT YOU MAINTAIN THE FACTORY CIRCUIT WHENEVER POSSIBLE. The following two circuits may be used only if the above circuit is not available.

NOTE: When completing an installation using either of the following key in sensor circuits, if the operator inserts the ignition key while the vehicle is running under the control of the Remote Start, the vehicle will shut down. This must be explained to the operator as it is in contrast to the normal operation of a vehicle utilizing an electrical neutral start switch and is inconsistent with the operators manual. Additional information concerning Key In Sensor methods 1 & 2 are listed below and should be reviewed before considering either alternative.

Method 1 will allow the safety required for the remote start unit and prevent the vehicle from starting while in any gear other than Park or Neutral while the key is in the ignition cylinder however, if the key is left in the ignition switch and the door is left opened, the added relay will be energized causing a 150mA drain on the battery.

Method 2 will allow the safety required for the remote start unit and prevent the vehicle from starting while in any gear other than Park or Neutral while the key is in the ignition cylinder however, the original factory key in chime module will not alert the owner that the key has been left in the ignition switch. In addition, this may also effect other warning tones such as the light on reminder.

These situations should be carefully considered before altering the vehicle's wiring and must be fully explained to the consumer.

METHOD 1

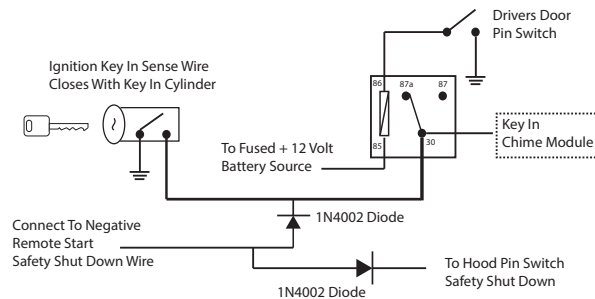

To connect to the key in sensor as shown in method 1:

- 1) Locate the control wire that connects the drivers door pin switch to the key in sensor switch.
- 2) Cut this wire and connect the ignition cylinder side to chassis ground.
- 3) Locate the key in sensor switch wire that connects the chime module to the ignition cylinder .
- 4) Cut this wire and connect the ignition cylinder side to terminal 30 of a P&B VF45F11 or equivalent relay.
- 5) Connect the cathode (striped) side of a 4002 series diode to this same wire, and connect the (non striped) side to the negative shut down safety wire (Gray / Black) of the Voxx Remote Start Unit.
- 6) Connect terminal 86 of the relay to a fused +12 volt constant battery source.
- 7) Connect terminal 87 of the relay to the Chime Module side of the previously cut wire in step D.
- 8) Connect terminal 85 of the relay to the Drivers Door side of the pin switch wire previously cut in step B.

NOTE: A second 4002 series diode may be required to maintain the integrity of the hood open, shut down circuit. If this is the case, it must be installed as shown in the diagram above. The anode (Non Striped) side must be connected to the Gray/Black wire of the Remote Start Unit. The cathode (Striped) side must be connected to the hood pin switch. If the hood pin switch is also used for an alarm trigger input, be certain to use the dual diode set up shown earlier in this manual.

METHOD 2:

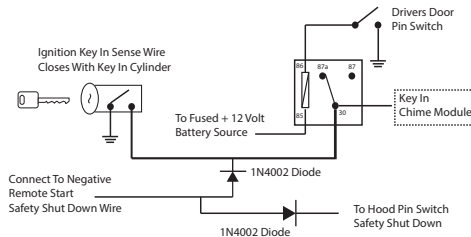

To connect to the key in sensor circuit as shown for method 2:

- 1) Locate the control wire that connects the drivers door pin switch to the key in sensor switch.
- 2) Cut this wire and connect the ignition cylinder side to chassis ground.
- 3) Locate the key in sensor switch wire that connects the chime module to the ignition cylinder .
- 4) Cut this wire and connect the ignition cylinder side to the Remote Start Negative Safety Shut down Wire Gray/Black, using a 4002 series diode as shown above.

NOTE: A second 4002 series diode may be required to maintain the integrity of the hood open, shut down circuit. If this is the case, it must be installed as shown in the diagram above. The anode (Non Striped) side must be connected to the Gray/Black wire of the Remote Start Unit. The cathode (Striped) side must be connected to the hood pin switch. If the hood pin switch is also used for an alarm trigger input, be certain to use the dual diode set up shown earlier in this manual.

AFTER THE CONNECTION OF THE NEUTRAL START SAFETY WIRE AS INDICATED IN ANY OF THE PREVIOUS ALTERNATE CONFIGURATIONS, THIS CIRCUIT MUST BE TESTED FOR PROPER OPERATION.

Retest by following the steps outlined in the NEUTRAL START SAFETY TEST section of the manual.

WIRING UP THE ARM / DISARM INPUTS IN VEHICLES WHEN THE SYSTEM IS USED AS A STAND ALONE PASSIVE (IGNITION CONTROLLED) ALARM SYSTEM

For this mode of operation, be certain to set selectable features of bank 2 #6 for passive arm, and #17 for 15 second this will allow the operator to enter the vehicle before the entry delay expires and turn the ignition on without the alarm system triggering.

Green/Black & Green Wires: (Arm #1 & #2 Inputs)
Connect both these wires to chassis ground.

Red Wire: (Disarm Input #1)
Connect this wire to an ignition source that has +12 VDC when the ignition is turned to the on and start positions and has "0 VDC" when the ignition key is in any other position.

Red/Black Wire: (Disarm Input #2)
Connect this wire to chassis ground.

Blue Wire: (Trunk Shunt Input)
Not used for the stand alone passive alarm application.

DOMES DELAY LEARN FEATURE:

This unit has the ability to learn the dome light delay time, up to 60 seconds. If the vehicle has delay interior lights, and you wish to avoid three chirp, defect zone, indication normally associated with this type of interior light, we suggest you learn the interior light delay.

To learn the light delay, start with all doors closed:

- 1) Use the transmitter to Lock / Unlock / Lock / Unlock / Lock / Unlock / Lock, the system. The LED turns on solid to confirm the system entered the learn mode.
- 2) Immediately open and close the door of the vehicle to initiate the dome delay. The unit will monitor the door trigger input Positive, (Purple), and Negative, (Brown) when active. When the dome light turns off, the unit will add 2 seconds then exit the learn mode.
- 3) The LED will begin flashing the Armed indication indicating the unit has exited the learn mode and is armed.

ADJUSTING THE SHOCK SENSOR:

If used, the sensitivity of the pre - detect circuit is automatically set 30% less sensitive than the full trigger circuit.

- 1) Using a small screwdriver, gently turn the adjustment screw fully counterclockwise. (DO NOT over turn this screw. Maximum rotation for this adjustment is 270°). Close the hood and trunk lids, and arm the alarm. Wait 6 seconds for the accessories trigger zone to stabilize, then firmly strike the rear bumper with the side of a closed fist considering the amount of force required to break a window.

CAUTION: Never perform this test on the vehicle's glass, as you may break the window.

- 2) Turn the adjustment screw clockwise (increasing sensitivity) about ¼ turn and re-test.
- 3) Repeat this procedure until the alarm sounds. Ultimately, one firm strike to the rear bumper will cause the alarm to emit pre-detect warning tones.

WARNING ! Setting the sensitivity too high can cause false alarms due to noise vibrations from passing trucks and heavy equipment. To decrease sensitivity, turn the adjustment screw counter clockwise.

COMPLETING THE INSTALLATION:

After you have confirmed the operation of the Remote Start unit and tested all the safety features of the system:

- 1) Mount the control module up and behind the dash securing it in place with cable ties or screws. Be certain that the chosen mounting location will not inhibit any of the controls of the vehicle.
- 2) Securely harness and tie all wiring up and away from all hot and moving parts that they may come in contact with under the dash board or in the engine compartment areas.

CAUTION: Particularly avoid the area around the steering shaft and column, as wires can wrap around these mechanisms and impair the safe operation of the vehicle.

- 3) Apply the Caution Labels supplied with this kit to a conspicuous area in the engine compartment. Make sure to clean the surface before affixing the label.
- 4) Check the vehicle's wipers, lights, horn, etc.... to insure proper operation.
- 5) Replace all panels that were removed during installation, and retest the system.
- 6) Explain all activated features and safety systems associated with the Remote Start Unit installed. Also point out the location of the Push-Button LED Override/Valet switch to the customer and explain it's operation.

Bank 2 Feature 13:

You will note in the feature selection table 2 # 13 is the selection for OR, and the selection for AND. In the OR configuration if either of the arm, or disarm wires have a state change, from their resting state, the circuit will invert and either arm or disarm dependent on it state before the wires were activated.

In the AND configuration, both wires must have a atate change from their resting state an arm or disarm to take place.

In the OR configuration a typical connection would be one lock wire to the Drivers Door Motor, and the other lock wire to the Drivers Door Switch along with one unlock wire to the drivers door motor, and the other unlock wire to the passenger motor. This will allow the unit to arm and disarm from the factory keyless entry transmitter and not be armed or disarmed from the in vehicle door switch.

In the AND configuration, if there is no door switch available or it is inaccessible, you can connect one lock wire to the drivers motor leg and the second lock wire to the parking light and the same with the 2 unlock wires connect one to the unlock motor leg, and the second to the parking light. Both these will typically be active from the factory transmitter but not from the door switch.

In either case, the factory transmitter should allow the circuit to arm and disarm, however, the in vehicle door switch should not. Please confirm proper operation once the unit is installed.

Bank 3 Feature 15 Shock Sensor Setting:

While under control of the remote start, this system can be programmed to allow you to shunt the vibration detector via the transmitter. Simply turn feature 15 of bank 3 to 3 chirps, shunt from TX.

Anytime after remote starting, if the lock button of the factory, or optional transmitter is used, the shock sensor will be shunted for the entire run cycle. It will resume normal operation after the remote start unit shuts off. This is not available on one button upgrade transmitters and in that case shunt works only with the factory transmitter lock button. If this setting is left for default setting 1 chirp, the sensor will be shunted upon initial start up and as long as there is vibration, once the vibration settles down + 5 seconds the sensor will be re-instated, the two chirp setting is to allow the shock sensor to be bypassed anytime the remote start is engaged.

The Optional RF DATA Converter Kit used with this upgrade system requires programming after installation. Follow the programming instructions packaged with the Data Converter kit. If you find you need to program new or additional transmitters follow the instructions below.

NOTE: In the feature programming modes, where indicated, "press transmitter lock button", the Factory Transmitter Lock button, the in vehicle Door Lock Switch, the Brake Pedal or the added RF Transmitter lock or in the case of 1 button the start buttons may be used.

The PRLLED packaged with the AS9234E is used to enter the programmable feature banks and enter and exit the valet/override modes. If using the optional RF Kit the LED and push-button on the upgrade kits receiver will be used to program new or additional transmitters only.

PROGRAMMING BANK 1

If using the Optional DATA Converter & RF Kit, to Program Transmitters:

- 1) Turn the ignition key to the on position.
- 2) Press and release the transmitter programming button, found on the windshield mount receiver, 3 times
- 3) Press & hold the Lock, or on 1 Button kit, the Start Button until the LED turns on solid. Repeat for each transmitter you want programmed.
- 4) Turn the ignition switch off.

The above action programs Lock, Unlock & or Start function for the system. Test your system by locking, unlocking, and then starting by pressing the appropriate button or the start button of the transmitter two times in succession.

PROGRAMMING BANK 2 (ALARM FEATURES):

To program Bank 2 Alarm Features,

- 1) Turn the ignition key to the on position.
- 2) Press and release the valet/programming switch 3 times (Siren Chirps).
- 3) Turn the ignition key off then on. (Siren Chirp Twice)
- 4) Press the pushbutton switch once to advance to feature 1, twice to advance to feature 2, etc.,, then use the lock, or (start button on 1 button transmitters), of the transmitter to select the feature setting.

Example to set passive arming:

- 1) Turn the ignition key to the on position.
- 2) Press and release the valet/programming switch 3 times (Siren Chirps).
- 3) Turn the ignition key off then on. (Siren Chirp Twice)
- 4) Press the pushbutton switch six times to advance to features 6, Pass/Act Arm, then use the transmitter button, door lock switch, brake pedal, or added RF Transmitter button to select two chirps "Passive Arm".
- 5) To exit the programming mode, turn the ignition key off. more than 6 seconds

Note: When set to active arm, if disarmed, the unit will rearm if a door is not opened within 30 seconds.

SELECTABLE FEATURES

The selectable features of this unit can be set manually as explained on the previous page, or with the VEPROG On-Line. Factory default settings are indicated by **BOLD** text.

Be certain to place a check mark indicating the method used in the box located on the last page of the owner's manual.

NOTE: Keyless Entry Models with no horn output will Flash the Parking Lights instead of chirp where chirp is indicated. Also, No data will be indicated if a feature is not available for a particular model. The unit will enter the feature but no selection will be available.

RF Programmable Feature Bank 1 Is For Transmitter Programming See DATA Converter R/F Kit Reference shown before Programming Bank 1 Reference.

RF Programmable Feature Bank 2 Is Alarm Selectable Features

Feature Selection	1 Chirp	2 Chirps	3 Chirps	4 Chirps	5 Chirps	6 Chirps
1st Door Lock/Unlock	0.5 Sec	3.5 S Lock & Unlock	0.5 S Lock, Dbl Unlock	Dbl Lock, 0.5S Unlock	Dbl Lock, Dbl Unlock	0.5 S Lock, 350mS Unlock
2nd Accessory Lock	Accy. Locks On	Accy. Locks Off				
3rd Accessory Unlock	Accy. Unlock Dr. Door	Accy. Unlock All Doors	Accy. Unlock Off			
4th Headlights	NA					
5th Passive Locks	Passive	Active				
6th Passive/Active Arm	Passive Arm	Active Arm				
7th Siren / Horn	Siren & Horn	Siren Only	Horn Only			
8th Horn Chirps	10 mS	16 mS	30 mS	40 mS	50 mS	
9th Override Method	Custom Code	Valet				
10th 2 Step Unlock	NA					
11th Chirp Delete From TX	NA					
12th Trigger Circuits	All On	Doors Off	Hood /Trunk Off	All Off		
13th Lock/Unlock Poll**	120 mS OR Unlock Dr. + Passenger Door	80 mS OR Unlock Dr. + Parking light	120 mS AND lock Dr. + Parking Light	80 mS AND Lock Dr. + Parking Lights		
14th Aux. Ch. 5 Select	NA					
15th Aux Ch. 6 Select	NA					
16th Aux. Ch. 7 Select	NA					
17th Trigger Delay	None	15 Seconds				
18th Data Port Select	DBI/VOXX TEL	ADSV/OXX TEL	DBI/ADS TEL	ADSV/ADS TEL		

When using the VEPROG with the module installed, you must access feature bank 5. Failure to do so will not allow feature programming of software updates. This is not necessary if programming the unit on the bench with no 12 VDC powering the module. To access bank 5 turn the ignition switch on, press the valet push-button 3 times, then turn the ignition off then on 4 times., the siren/horn will chirp 5 times indicating feature bank. (in vehicle programming) is accessed. Connect the VEPROG and perform the functions required. Once complete, disconnect the VEPROG from the module, then turn the ignition switch off more than 6 seconds to exit the feature programming bank.

**** Feature 13.** Lock & Unlock polling refers to the wires and timing of the analog inputs Lock 1 & 2 and Unlock 1 & 2. In the OR configuration either of these wires, when they change states, the unit will disarm either with a pulse of 80 or 120 mS, as selected. In the AND configuration, both wires must change states in order for the unit to disarm either with a pulse of 80 or 120mS as selected. Typically OR is used when connecting to the driver door motor and the driver door switch, and the AND is used when connecting to the door unlock and the parking lights if the lights turn on when the factory transmitter is used.

PROGRAMMING BANK 3 (REMOTE START):

You can enter Bank 3 from Bank 2 by turning the ignition key off then on after you've made the changes you wanted in Bank 2, (Siren Chirp 3 Times), You can also go right to bank 3 by:

- 1) Turn the ignition key to the on position.
- 2) Press and release the valet/programming switch 3 times (Siren Chirps).
- 3) Turn the ignition key off then on. (Siren Chirp Twice)
- 4) Turn the ignition key off then on. (Siren Chirps 3 Times)
- 5) Press the pushbutton switch once to advance to feature 1, twice to advance to feature 2, etc.,,then use the lock button of the transmitter to select the feature setting.

Example to set engine input check to DBI Tach:

- 1) Turn the ignition key to the on position.
- 2) Press and release the valet/programming switch 3 times (Siren Chirps).
- 3) Turn the ignition key off then on. (Siren Short Then long Chirp)
- 4) Turn the ignition key off then on. (Siren two Long Chirp)
- 5) Press the pushbutton switch five times to advance to features 5, Input Check, then use the transmitter button, either lock, or start in the case of 1 button transmitters, door lock switch, or brake pedal to select three chirps, "DBI Tach"
- 6) To exit the programming mode, turn the ignition key off for more than 6 seconds.

Bank 4 is for Custom Code Programming (Refer to Custom Code Programming Section)
Bank 5 is for Programming features and software while the module is connected to +12 Volts. (Refer to VEPROG instruction & Information.

TACH RATE PROGRAMMING:

1. Turn the ignition key to the On position.
2. Press and release the valet/program push button switch 3 times.
3. Immediately turn the ignition key Off.
4. Press and hold the valet/program push button switch, then start the vehicle using the key.
5. When the unit senses the tach signal, the parking lights will begin to flash.
6. Release the valet/program pushbutton switch. The parking lights will turn on for three seconds to indicate that the learned tach signal is stored and the unit is out of the tach learn mode.

NOTE: If the unit fails to learn tach rate due to an improper tachometer connection or a poor tach source, the parking lights will not flash. To correct this situation, locate and connect the Green/Orange wire to the proper tach signal, and then repeat the tach learn routine.

RF Programmable Feature Bank 3 Is Remote Start Selectable Features:

Feature Selection	1 Chirp	2 Chirps	3 Chirps	4 Chirps	5 Chirps	6 Chirps
1st Defrost Output	NA					
2nd RF Start Chirps	Off	On	On & Car Finder			
3rd Run Time	5 Mins	10 Mins	15 Mins	20 Mins	45 Mins	60 Mins
4th Parking Lights	On Steady	Flashing				
5th Input Check	Voltage	Tachometer	DBI Tachometer	Hybrid		
6th Voltage Level	>0.5V Before Start	<0.5V Before Start				
7th Ignition 2 Select	Off During Crank	On During Crank	Same As Accy.			
8th Ignition 3 Select	NA					
9th Accessory Relay	Off During Crank	On During Crank	Same As Starter			
10th Diagnostics	Off	On				
11th Crank Time	0.8 Sec	1.0 Sec	1.5 Sec	2.0 Sec	3.0 Sec	4.0 Sec
12th Gas/Diesel	Gas	Diesel 10 Sec	Diesel 15 Sec	Diesel 20 Sec		
13th Temp Start	NA					
14th Crank Averaging	Averaging	Preset Time				
15th Shock Sensor During R/S	Shunt Until Clear	Shunt R/S Cycle	Shunt From TX			
16th Turbo Select	NA					
17th One or Two Press Start	NA					
18th Door Lock Control	No Change	U/L B4 Start Lock After Start	Unlock Before Start	Lock After Start		
19th Alt O/P Feature Set BS Black/Blue	Single Pulse	As Feature 1 Bank 2	350mS Pulse	500mS Pulse	800mS Pulse	
20th Alt O/P Feature Set DC Black/Yellow	During Crank	Ground When Running	O/P Same As Ignition 1	O/P Same As Accy.		
21st Alt O/P Feature Set AS Black/Lt. Green	Pulse After Start	Ground When Running	O/P Same As Ignition 1	O/P Same As Accy.	During Crank	
22nd Alt O/P Feature Set ASD Black/Red	Pulse After Shut Down	Ground When Running	O/P Same As Ignition 1	O/P Same As Accy.	During Crank	
23rd Ignition and Accy. Relays	No Pulse w/Unlock	Pulse Ign. Accy. & GWR w/Unlock	Pulse Ign. Accy. & GWR w/Unlock, Follow 1 Second Later w/ASD Pulse			

Note : When feature #5 is set for Voltage mode the unit must also have feature #14 set for Averaging and the vehicle started manually at least 4 times or the unit will flash the Pk. Lts. 7 times and not start.

When using the VEPROG with the module installed, you must access feature bank 5. Failure to do so will not allow feature programming of software updates. This is not necessary if programming the unit on the bench with no 12 VDC powering the module. To access bank 5 turn the ignition switch on, press the valet push-button 3 times, then turn the ignition off then on 4 times,...the siren/horn will chirp 5 times indicating feature bank, (in vehicle programming) is accessed. Connect the VEPROG and perform the functions required. Once complete, disconnect the VEPROG from the module, then turn the ignition switch off more than 6 seconds to exit the feature bank.

